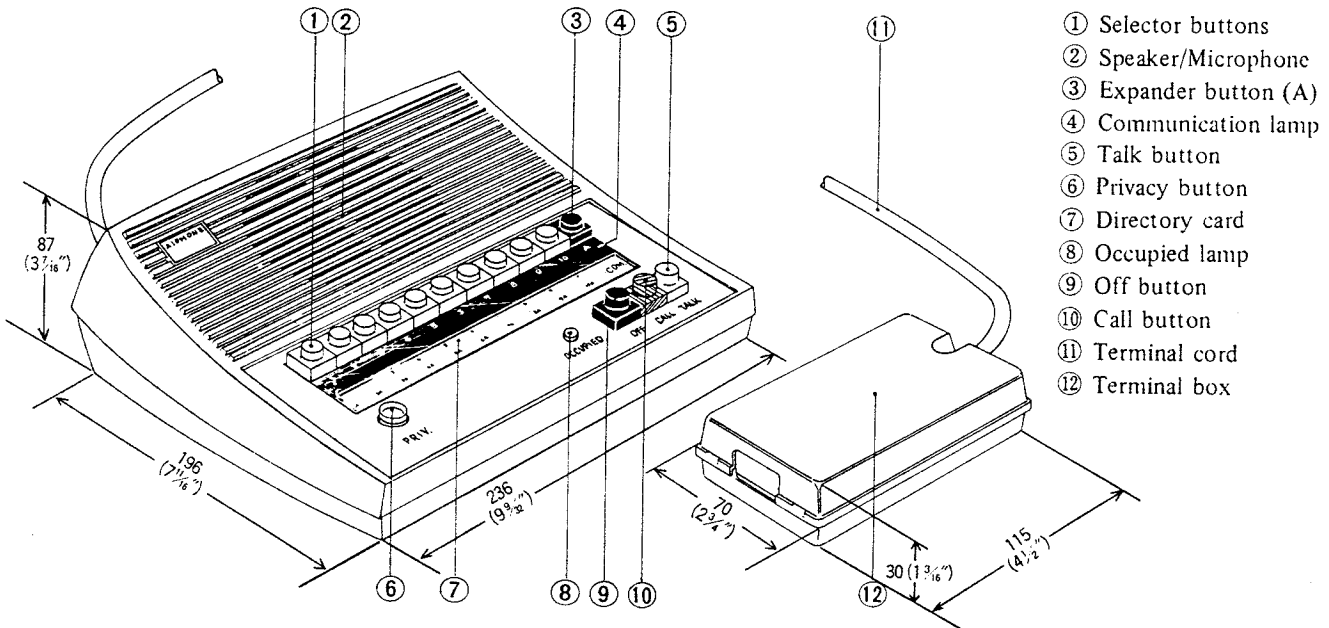
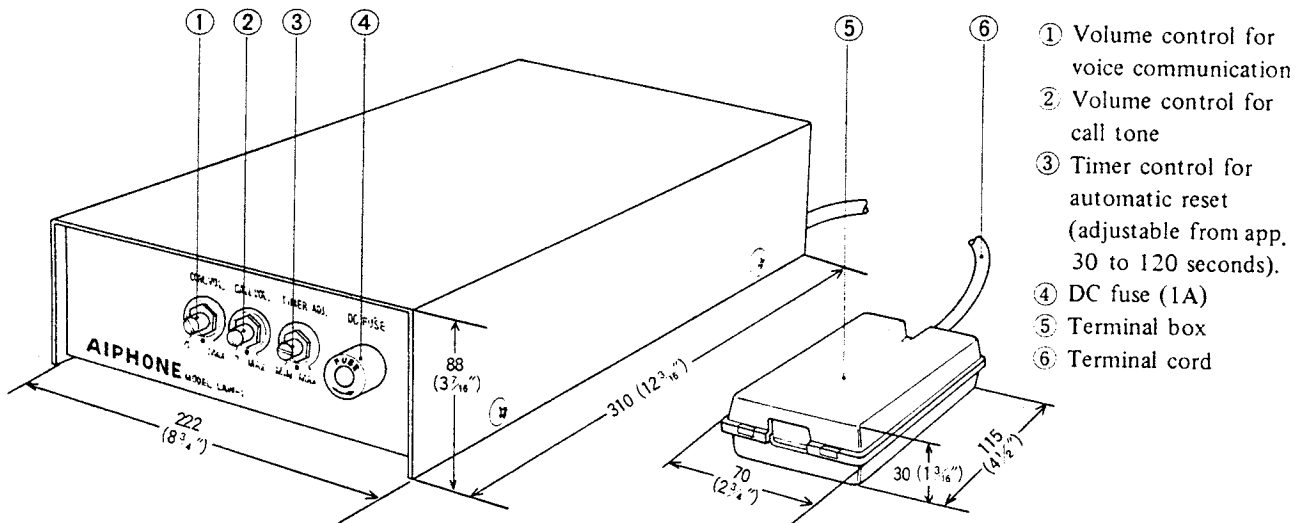

**CENTRAL AMPLIFIER SYSTEM****MODELS LAH-20** (twenty-way master station)**LAW-1** (central amplifier)**— INSTRUCTIONS —****LAH-20**

- ① Selector buttons
- ② Speaker/Microphone
- ③ Expander button (A)
- ④ Communication lamp
- ⑤ Talk button
- ⑥ Privacy button
- ⑦ Directory card
- ⑧ Occupied lamp
- ⑨ Off button
- ⑩ Call button
- ⑪ Terminal cord
- ⑫ Terminal box

**LAW-1**

- ① Volume control for voice communication
- ② Volume control for call tone
- ③ Timer control for automatic reset (adjustable from app. 30 to 120 seconds).
- ④ DC fuse (1A)
- ⑤ Terminal box
- ⑥ Terminal cord

## SPECIFICATIONS

- \* Power source: DC 12 volt. Use PS-12A (or PS-12C in North America) power supply.
- \* Current consumption: 1A maximum during talking per system.
- \* Amplifier output: 800 mW maximum.
- \* Calling: Push button station selection. Occupied lamp illuminates if the system is in use.
- \* Wiring: 7 twisted pairs are required regardless of the number of installed stations. Each pair must be twisted.

## FEATURES

- \* The central amplifier uses advanced integrated circuits providing excellent fidelity and trouble-free operation.
- \* Automatic reset ensures that a station left on will not occupy the system (a warning tone sounds before the system automatically resets).
- \* A local privacy button and incoming call tone prevent monitoring.
- \* Warning tone to both parties when called station is in privacy.
- \* Single channel amplifier positively locks out a third party.
- \* Hands-free reply at called station.
- \* Binary computer circuit permits 20 stations to be connected using only 7-pair cable.
- \* Tone and communication volume controls are located on the central amplifier.
- \* Designed for desk or wall mounting (desk only with handset).
- \* Field installed handset provides privacy at calling or receiving stations.
- \* An extension talkback speaker may be connected to a LAH-20 station with LAN-1 adaptor.

## EQUIPMENT AVAILABLE FOR USE WITH YOUR LAH CENTRAL AMPLIFIER SYSTEM



LAH-20: 20 call master station.



LAN-1: Extension talkback speaker adaptor. Connects LAH-20 master station to a paging horn or speaker.



LAW-1: Central amplifier.



PS-12C: CSA & UNDERWRITERS' LABORATORIES, INC. Listed power supply (available only in N. America).



LAR-1: Optional handset. Includes press-to-talk switch.



PS-12A: Power supply (not available in North America).

WRITE WIRING COLOR CODE HERE

## INSTALLATION

Do not attempt to install your intercom system until you have read and thoroughly understood the installation procedure. Aiphone's warranty is void if system is installed in a manner other than described in this manual.

## WIRING

Lay out your system in advance and determine a location of each station. Please refer to the chart below to select proper size wire for your installation. 7 twisted pairs of wire are required regardless of the number of installed stations.

| AWG WIRE SIZE                                         | 24 AWG | 22 AWG  | 20 AWG | 18 AWG |
|-------------------------------------------------------|--------|---------|--------|--------|
| COMMUNICATION DISTANCE FROM EACH STATION TO AMPLIFIER | 300'   | 500'    | 760'   | 1200'  |
| DIAMETER OF WIRE                                      | 0.5 mm | 0.65 mm | 0.8 mm | 1.0 mm |
| COMMUNICATION DISTANCE FROM EACH STATION TO AMPLIFIER | 90 m   | 150 m   | 230 m  | 360 m  |

Total length of all communication wire installed per system should not exceed 2km or 1.25 mile.

Refer to the wiring diagram and write your color code in a space provided. Begin with the central amplifier and wire the first two stations, testing them after installation. Unplug power supply while making connections. Refer to the table on the bottom of each station to assign that station's number.

# LAH-20 ALL MASTER SYSTEM with L

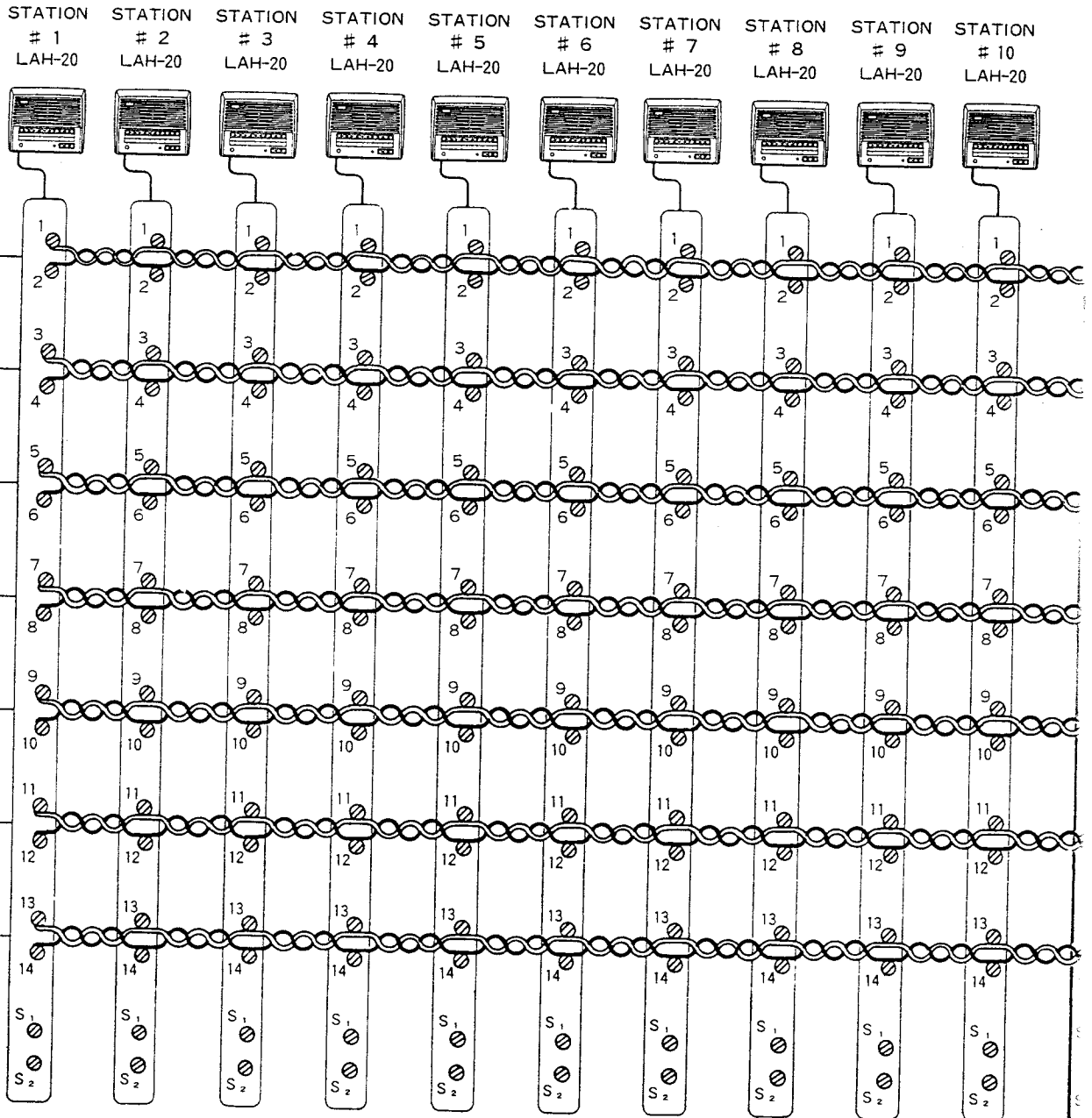

## WIRING INSTRUCTIONS

- 1) Use 7 twisted pair cable.
- 2) Each twisted pair must be connected to terminals #1 and #2, #3 and #4, #5 and #6, etc. Please refer to wiring diagram.
- 3) Wiring may be in a loop as shown above, or in a home-run manner.
- 4) We advise installing amplifier near the center of the system.
- 5) Connect the red and black wires within the amplifier to plus (+) and minus (-) respectively of the power supply. The power supply may be mounted inside the amplifier cabinet.

**CAUTION:** DO NOT ATTEMPT TO CONNECT POWER SUPPLY TO LAH-20 MASTER STATION.

## INSTALLATION FOR WALL MOUNTING

- 1) Attach the mounting bracket to wall or plaster ring.
- 2) Attach the master station to this mounting bracket.

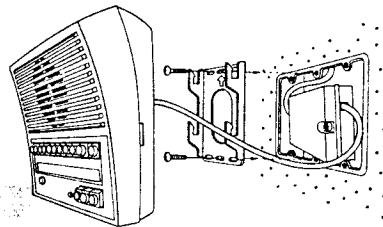

# LAH-20 LAW-1 CENTRAL AMPLIFIER

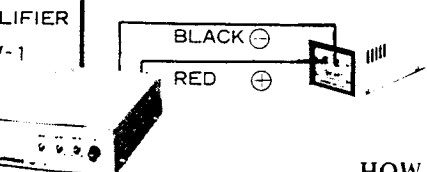
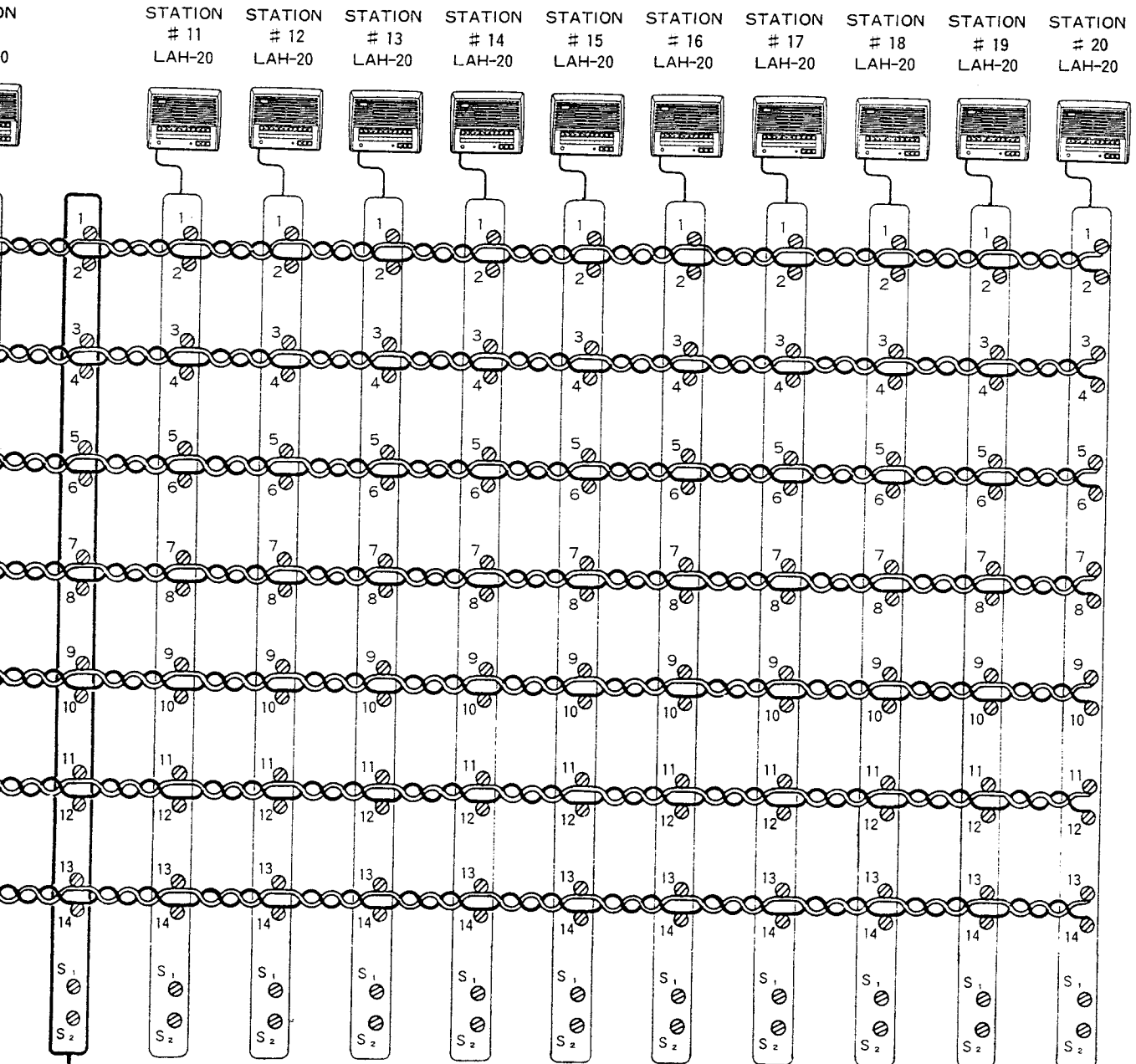

PS-12A or  
PS-12C  
POWER SUPPLY  
DC-12V

STATION NUMBER CODING SWITCH

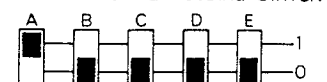

## HOW TO SET THE BINARY COMPUTER

Please refer to the table to assign station numbers to each of the intercom masters (Note: This same table is on the bottom of each master). Each intercom will have a separate number, that is, station #1 will be programmed for one intercom, station #2 for the next and so on until all stations have been programmed. For example, to program an intercom for station #1, just refer to the ST No. 1 on the chart and set "A" switch to 1 position and set the remaining switches "B", "C", "D" and "E" to the 0 position.

| A | B | C | D | E | ST.No. |
|---|---|---|---|---|--------|
| 1 | 0 | 0 | 0 | 0 | 1      |
| 0 | 1 | 0 | 0 | 0 | 2      |
| 1 | 1 | 0 | 0 | 0 | 3      |
| 0 | 0 | 1 | 0 | 0 | 4      |
| 1 | 0 | 1 | 0 | 0 | 5      |
| 0 | 1 | 1 | 0 | 0 | 6      |
| 1 | 1 | 1 | 0 | 0 | 7      |
| 0 | 0 | 0 | 1 | 0 | 8      |
| 1 | 0 | 0 | 1 | 0 | 9      |
| 0 | 1 | 0 | 1 | 0 | 10     |
| 1 | 0 | 0 | 0 | 1 | 1A     |
| 0 | 1 | 0 | 0 | 1 | 2A     |
| 1 | 1 | 0 | 0 | 1 | 3A     |
| 0 | 0 | 1 | 0 | 1 | 4A     |
| 1 | 0 | 1 | 0 | 1 | 5A     |
| 0 | 1 | 1 | 0 | 1 | 6A     |
| 1 | 1 | 1 | 0 | 1 | 7A     |
| 0 | 0 | 0 | 1 | 1 | 8A     |
| 1 | 0 | 0 | 1 | 1 | 9A     |
| 0 | 1 | 0 | 1 | 1 | 10A    |

## INSTALLATION OF LAR-1 OPTIONAL HANDSET

- 1) Remove four screws on the bottom of master station and lift the plastic case from the base.
- 2) Using a sharp knife, cut open between terminals A & B, and also C & D on the printed circuit board.
- 3) Using 8mm (1/4") drill or soldering iron, make a hole to pass conductors into the body of master station.
- 4) Mount the handset to body of master station with supplied screws.
- 5) Connect the nine conductors from the handset to the printed circuit board. For full information please refer to the instruction sheet packed with LAR-1.

NOTE: The LAH-20 master station with LAR-1 handset can not be mounted to wall.

## LAH-20 SYSTEM WITH EXTENSION TALKBACK SPEAKER USING LAN-1 ADAPTOR

- \* Each LAH-20 master may be connected to one extension speaker.
- \* One extension speaker may be connected up to three LAH-20 masters but requires one LAN-1 adaptor per each master.
- \* Extension speaker requirements: Either AIPHONE MODEL LA-A standard substation (speaker output 0.8W max.), or locally available a 8 ohm paging horn (speaker output 1.2W max.) or a 16 ohm paging horn (speaker output 1W max.) may be used.

NOTE: The call switch in the LA-A can not be used.

- \* Wiring: Connect yellow, blue, black, white and red wires from LAN-1 to 5, 6, 14, S1 and S2 terminals on the LAH-20 and then yellow and blue wires from the secondary side of LAN-1 to the extension speaker.
- \* In this example buttons #8-A on station #18 selects LA-A extension speaker and buttons #9-A on station #19 and buttons #10-A on station #20 select paging horn.

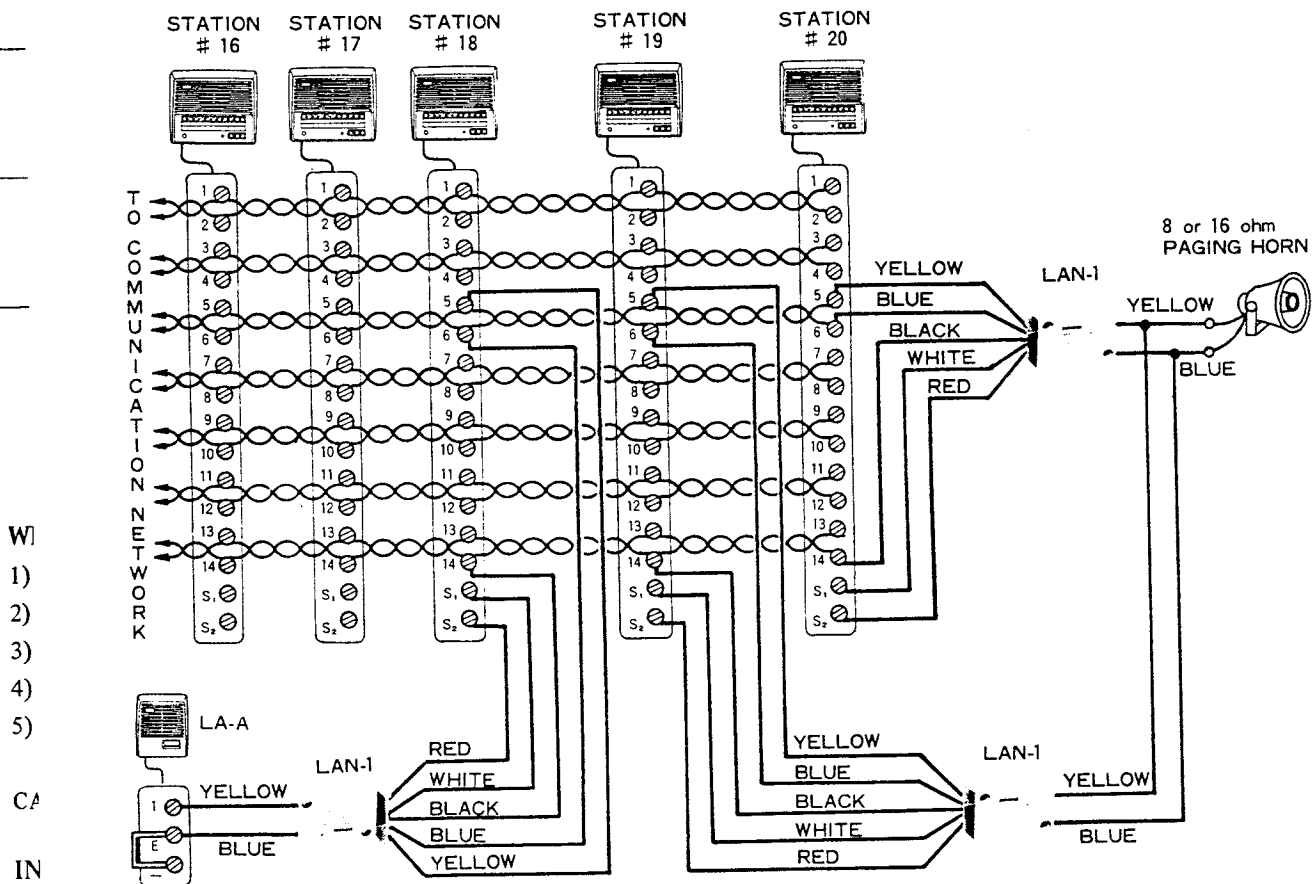

NOTE: LAN-1 adaptor should be located near the LAH-20 master.

Distance from the LAH-20 master to extension speaker must not exceed 150m (450').

## OPERATION

### \* Calling;

- 1) If the occupied lamp is not illuminated, select the station desired by depressing the proper button. Station #11 through #20 are called by depressing the number button and then the expander button (A). Station #11 is 1-A, Station #12 is 2-A, etc.
- 2) Depress call button to establish communications and signal the called station.
- 3) If a steady tone is heard, the called station is in privacy. By pressing the call button, the called station will be notified that it is in the privacy mode.
- 4) Use the talk button to control communications. If using the optional handset, use the talk switch in the handset to control communications.
- 5) Depress the OFF switch at the end of every conversation (the selector button may remain in depressed position). If you forget to depress the OFF switch, a warning tone will notify you that your station is on.

### \* Receiving;

The open voice feature allows handsfree operation. The privacy switch locks out monitoring or eavesdropping. The call light will illuminate, however, even if in privacy, and call tone will sound. The call may be answered by releasing the privacy switch or by using the handset.

### \* To call extension speaker;

Extension speaker, if installed to your LAH-20 master, may be called by depressing the selector button corresponding to your station number and then the call button. Selector button #1 on master #1, selector button #2 on master #2, etc. selects respectively each speaker. Operation is exactly same as communication with other master station.

## CLEANING YOUR INTERCOM STATIONS

- \* Your Aiphone intercom stations may be cleaned with a soft cloth dampened with household cleanser, such as Mr. Clean or Fantastik.

\* \* \*

We at AIPHONE are proud of our products. Our designers and engineers strive to bring you the finest in communication equipment. Each item has been carefully tested and inspected before leaving our factory. Properly installed and used, your Aiphone intercom system should give years of troublefree service.

We are pleased to offer the following warranty:

### WARRANTY

Aiphone warrants its products to be free from defects of material and workmanship under normal use and service for a period of one year after delivery to the ultimate user and will repair free of charge or replace at no charge, should it become defective upon which examination shall disclose to be defective and under warranty. Aiphone reserves unto itself the sole right to make the final decision whether there is a defect in materials and/or workmanship; and whether or not the product is within the warranty.

This warranty shall not apply to any Aiphone product which has been subject to misuse, neglect, accident, or to use in violation of instructions furnished, nor extended to units which have been repaired or altered outside of the factory.

This warranty does not cover batteries or damage caused by batteries used in connection with the product.

This warranty covers bench repairs only, and any repairs must be made at the shop or place designated in writing by Aiphone. Aiphone will not be responsible for any costs incurred involving on site service calls.

Aiphone Co., Ltd., Nagoya, Japan  
Aiphone U.S.A., Inc., Bellevue, Washington  
LAH-20 I-0278 ©

ALL OVER THE WORLD **AIPHONE**  
PRINTED IN JAPAN