

## TELEPHONE TYPE INTERCOM TA-F TYPE A SERIES

MODELS TA-1F TYPE A (single-way) TA-3F TYPE A (three-way)  
 TA-6F TYPE A (six-way) TA-12F TYPE A (twelve-way)

COMMON TALK

SELECTIVE RING

### - INSTRUCTIONS -

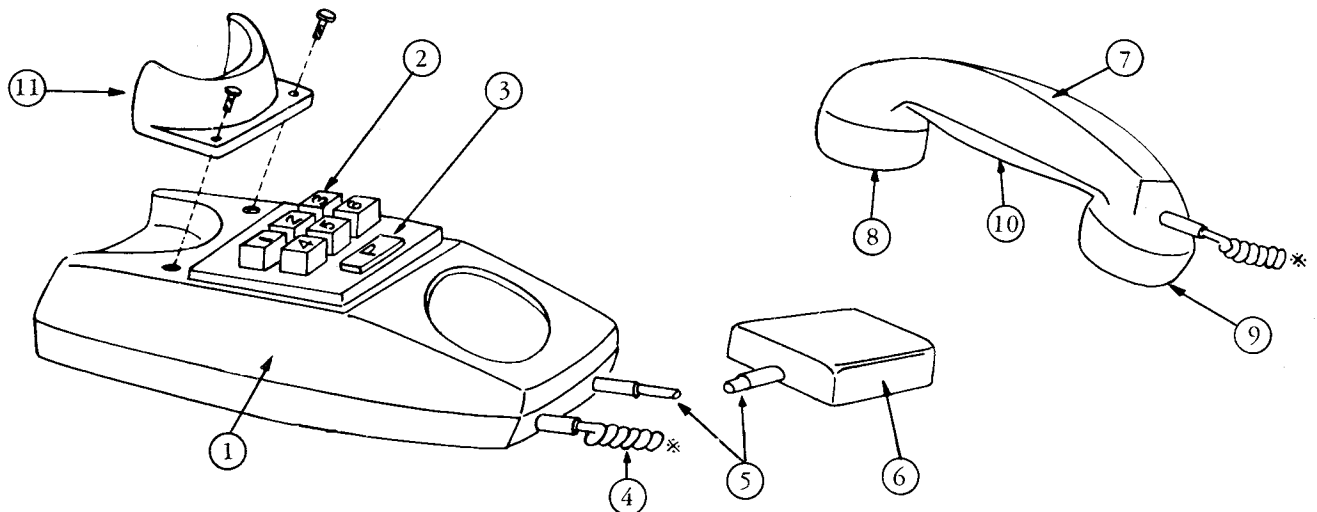

### NAMES AND FUNCTIONS

- |                            |   |
|----------------------------|---|
| ① Case                     | ⑦ Handset                                     |
| ② Station selector buttons | ⑧ Receiver                                    |
| ③ Paging button            | ⑨ Microphone                                  |
| ④ Coil cord                | ⑩ Directory card                              |
| ⑤ Terminal cord            | ⑪ Receiver cradle for wall mounting, included |
| ⑥ Terminal box             |   |

### SPECIFICATIONS

- \* Power source: DC 12 volt. Use PS-12S (PS-12C in North America) AC adaptor.
- \* Current consumption: 65 mA maximum at calling; 25 mA at talking.
- \* Calling: Push-button station selection. An electronic tone sounds when the selected station button is depressed.
- \* Paging: Use PG-U TYPE A paging adaptor in conjunction with standard paging amplifier and speakers
- \* Wiring: Up to 18 conductors may be required. Please refer to wiring diagram showing system that meets your requirements.

### FEATURES

- \* Up to 13 selective ring stations can be connected in a system.
- \* Single channel common talk system. Conference calls can selectively include up to 13 stations.
- \* Phone designed for either desk use or wall mounting.

- \* Door station TC-D TYPE A can be installed with adaptor DF-U TYPE A to master stations TA-3F TYPE A, TA-6F TYPE A, or TA-12F TYPE A. (Up to two door stations may be connected to up to 5 masters.)
- \* Phone system may be connected to existing paging and background music system using adaptor PG-U TYPE A
- \* Talkback paging available through existing paging system using adaptor PA-B.

## INSTALLATION

Do not attempt to install your intercom system until you have read and thoroughly understood the installation procedure. Aiphone's warranty is void if system is installed in a manner other than described in this manual.

Lay out your system in advance. Determine the exact location of each station. We recommend a full complement of wire be installed, even though you may not initially be installing the maximum number of stations available to your system. This way, should you decide to add a station later, you can avoid running additional cables to existing stations. Do not connect wires to terminals D1 or D2 unless appropriate equipment is used. Phone system will not operate if these wires are connected in parallel through system.

## WIRING REQUIRED

TA-1F - 5 Conductors maximum  
TA-3F - 9 Conductors maximum

TA-6F - 12 Conductors maximum  
TA-12F - 18 Conductors maximum

Refer to the chart below and select the proper wire gauge to meet your requirements.

AWG WIRE SIZE	24 AWG	22 AWG	20 AWG	18 AWG
DISTANCE	1300'	2100'	3300'	5300'
DIAMETER OF WIRE	0.5 mm	0.65 mm	0.8 mm	1.0 mm
DISTANCE	400 m	650 m	1000 m	1450 m

Begin your installation with station #1. A space is provided at the left of the diagram to write in your color code. Note the position of the C terminal at each station. Be sure you wire each station correctly.

After installing your second station we recommend that the power supply be connected to the + and - terminal lines at a convenient location and that a test be made for calling and talking between each station. As each additional station is installed re-test between each station. Unplug power supply while making wiring connections.

## ACTUAL TA-F TERMINAL LOCATIONS

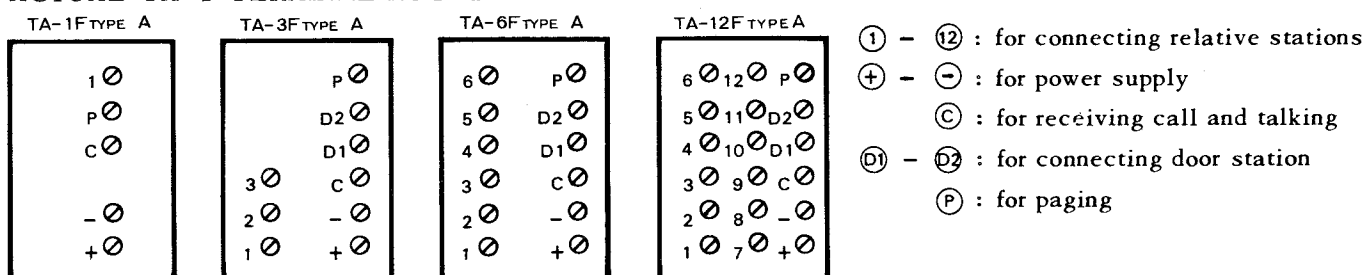

## INSTALLATION FOR WALL MOUNTING

- 1) Attach the mounting bracket to wall or single gang plaster ring.
- 2) Attach handset cradle included, as shown in illustration.

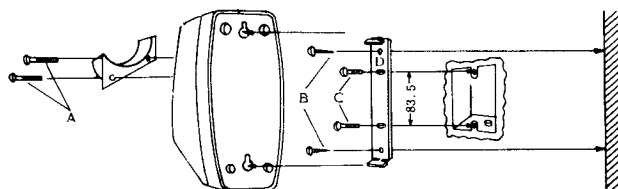

## EQUIPMENT AVAILABLE FOR USE WITH YOUR TA-F TYPE A PHONE SYSTEM



TA-1F TYPE A : 1 call master station with paging button.



TA-3F TYPE A : 3 call master station with paging button and door station capability.



TA-6F TYPE A : 6 call master station with paging button and door station capability.



TA-12F TYPE A : 12 call master station with paging button and door station capability.





TC-D Type A: Surface or semi-flush mount door station with push button for calling connected master.





DF-U TYPE A: Adaptor for door station. Required between door station TC-D TYPE A and TA-F TYPE A stations.

 SP-3: Paging speaker. Complete and ready to install including round flush mounting frame. Transformer installed for 70V line operation.  
(Not available in North America)

 N-S: Square frame for SP-3 speaker.

 N-E: Round surface frame for SP-3 speaker.

 PS-12C: CSA & UL LISTED power supply (available only in North America).

 RY-AC TYPE A; Relay for operating external device such as additional calling buzzer or bell, door release, etc.

 PG-U TYPE A: Paging adaptor for connecting any amplifier and background music source to your TA-F system. Features paging volume, treble & bass controls and automatic background music cut out.

 PS-12S: Power supply for system. Standard everywhere except in North America.

 EL-9S: Electric door release. Requires separate transformer and RY-AC.

 PA-B: Talkback paging adaptor.

 NCH-1: Noise cancelling handset especially designed to allow Aiphone TA-F phone system to operate in extremely noisy areas. Field installed only.

**TA-6F TYPE A: WITH TWO DOOR STATIONS CONNECTED.**

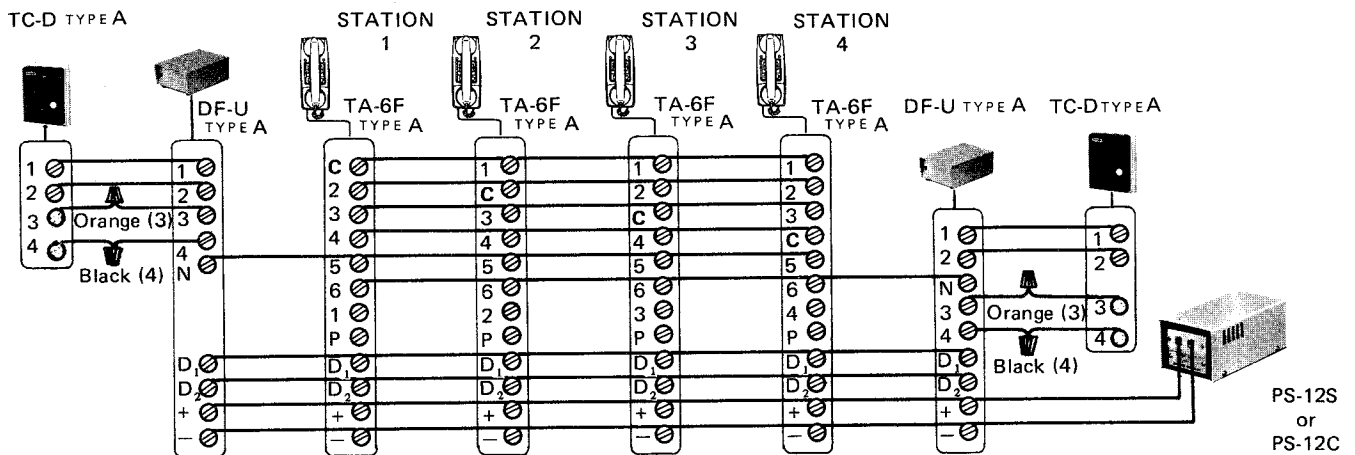

- NOTE: 1. Example above shows 4TA-6F TYPE A phones. 1 additional phone may be added if required.  
2. Maximum of 2 door stations may be connected to up to 5 phones per system.  
3. Do not use terminal #1 on each phone for communication with door station.

OPERATION: When call tone is heard at master, lift handset and press button No. 4 (or No. 5) once and begin conversation.

# TA-12F TYPE A ALL MASTE

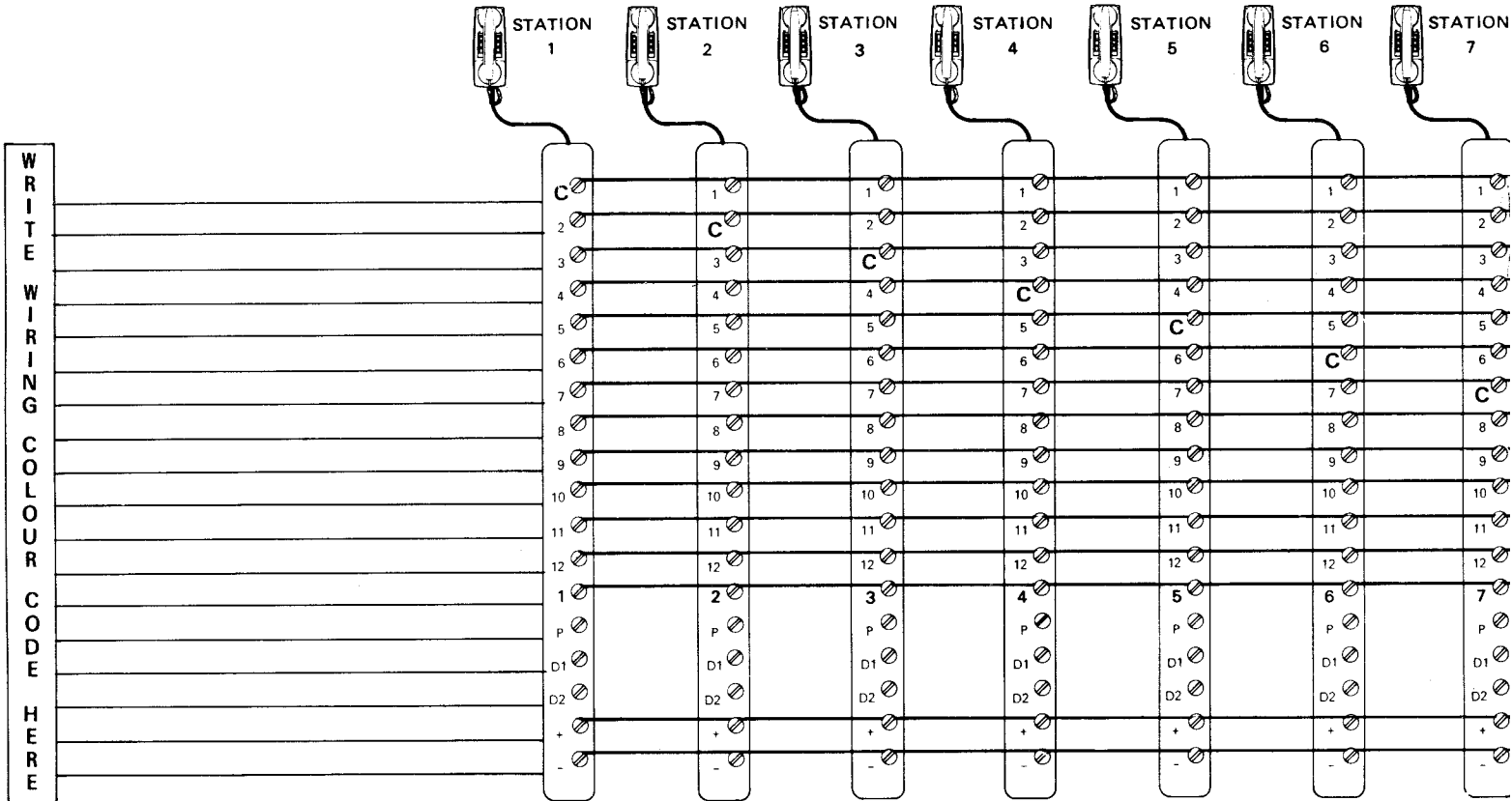

# TA-12F TYPE A PHONE SYSTEM with PAGING

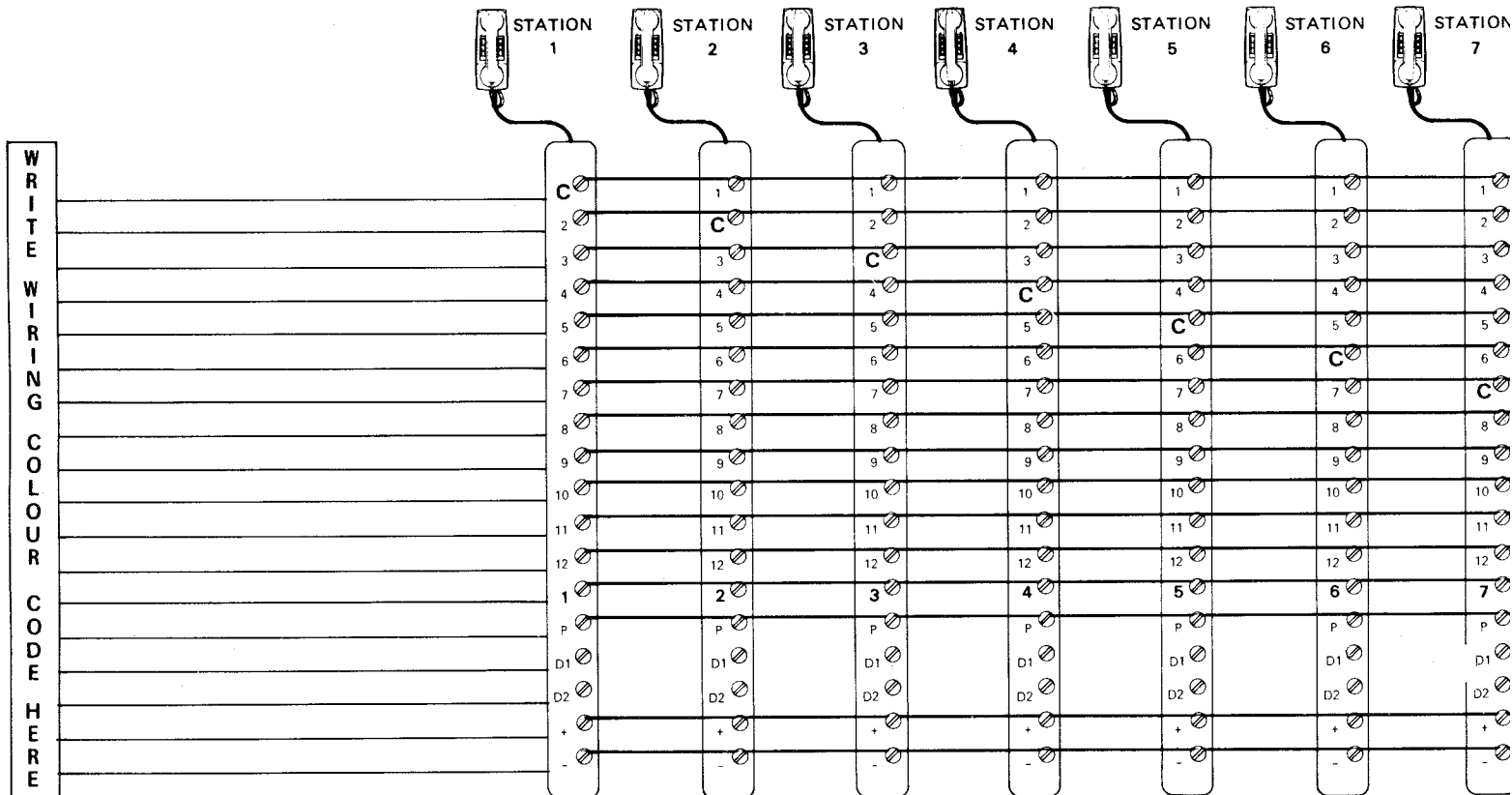

# R PHONE SYSTEM

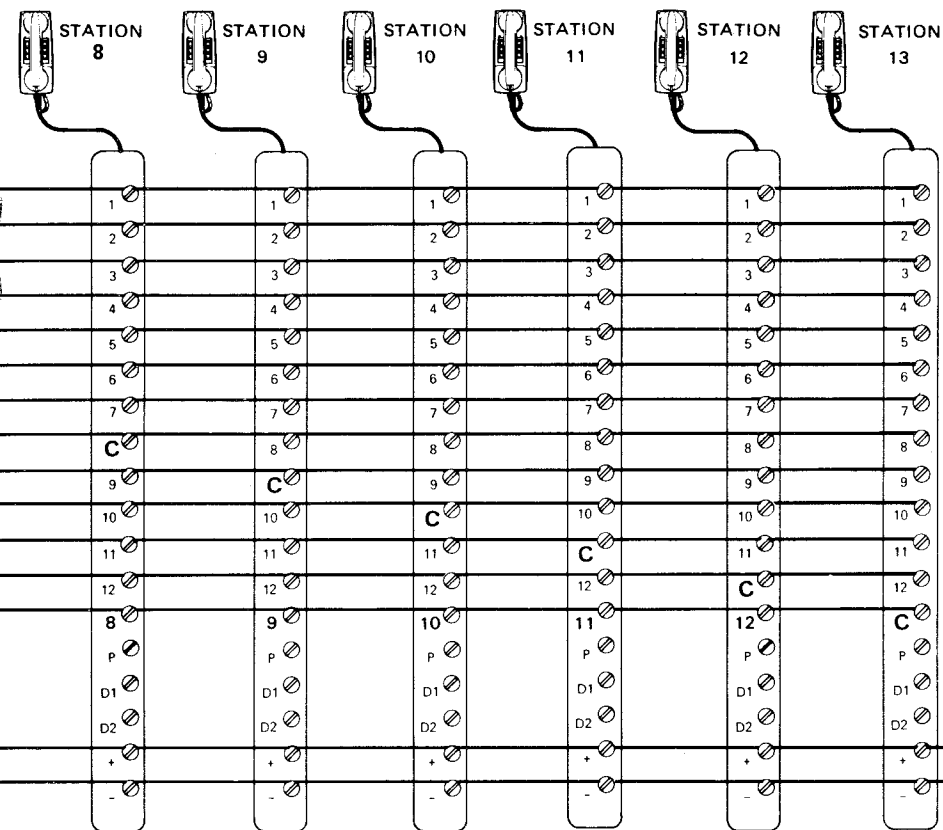

PS-12S or  
PS-12C

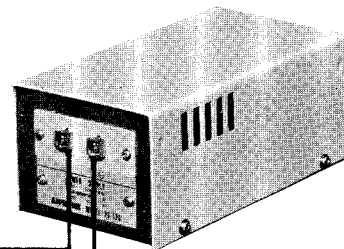

# and BACKGROUND MUSIC SYSTEM

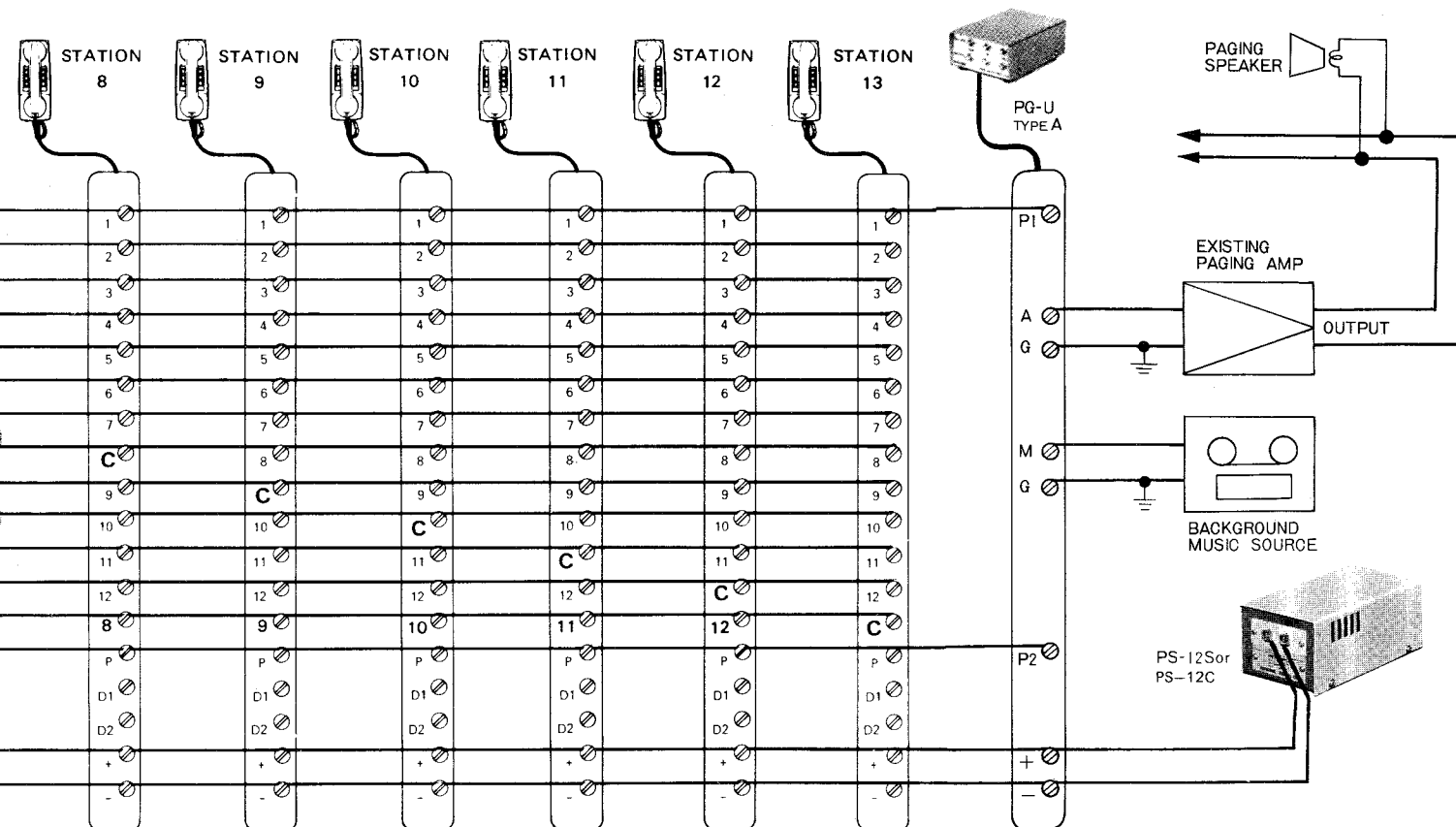

# TA-6F TYPE A SYSTEM WITH DOOR STATION & ELECTRIC DOOR RELEASE

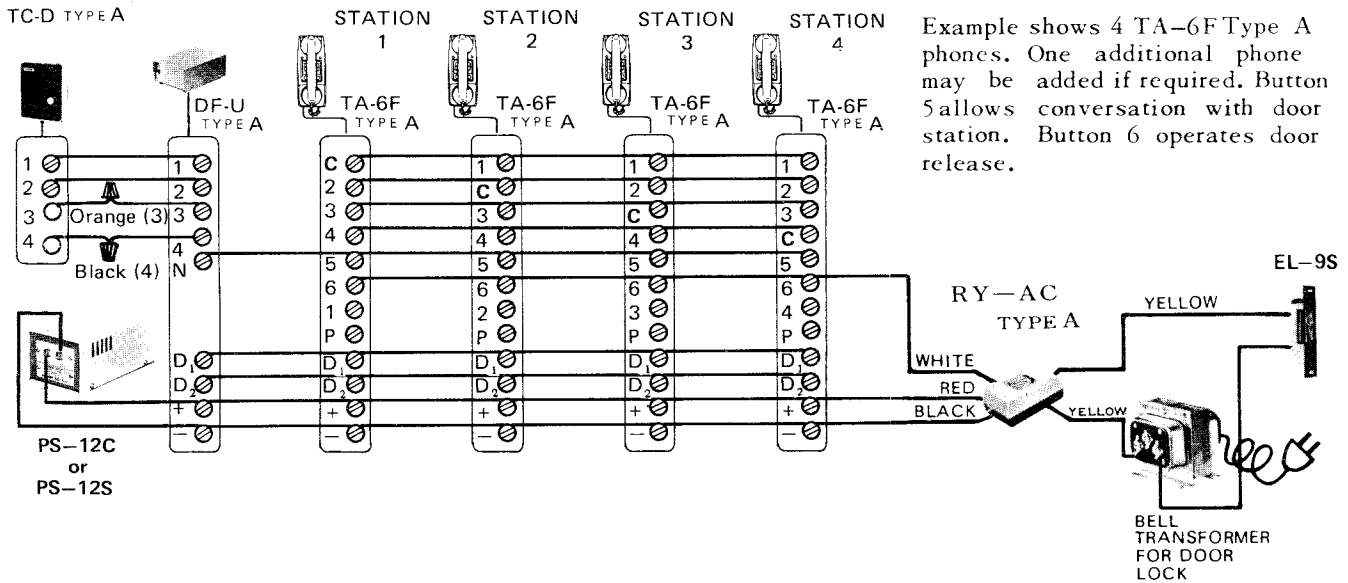

## WIRING DOOR RELEASE EL-9S

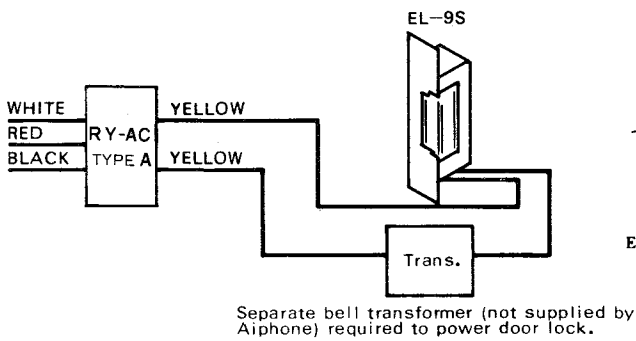

## AVAILABLE CYLINDRICAL LOCKS

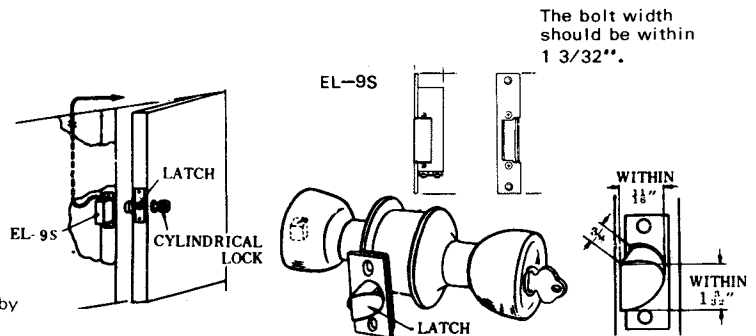

# TA-F TYPE A INTERCOM SYSTEM WITH TALKBACK PAGING

## EQUIPMENT REQUIREMENTS

- 1) TA-F system shall consist of TA-3F, TA-6F or TA-12F phones. TA-1F will not operate with talkback paging adaptor PA-B.
- 2) One PS-12C, one PG-U TYPE A, one PA-B, one paging amplifier with 70 volt line and output of less than 50 watt RMS, and appropriate paging speakers as required must be used.
- 3) Door station adaptor DF-U TYPE A and TC-D TYPE A door station can not be included in system when installing talkback paging adaptor PA-B.

For the full information, please refer to PA-B instruction sheet.

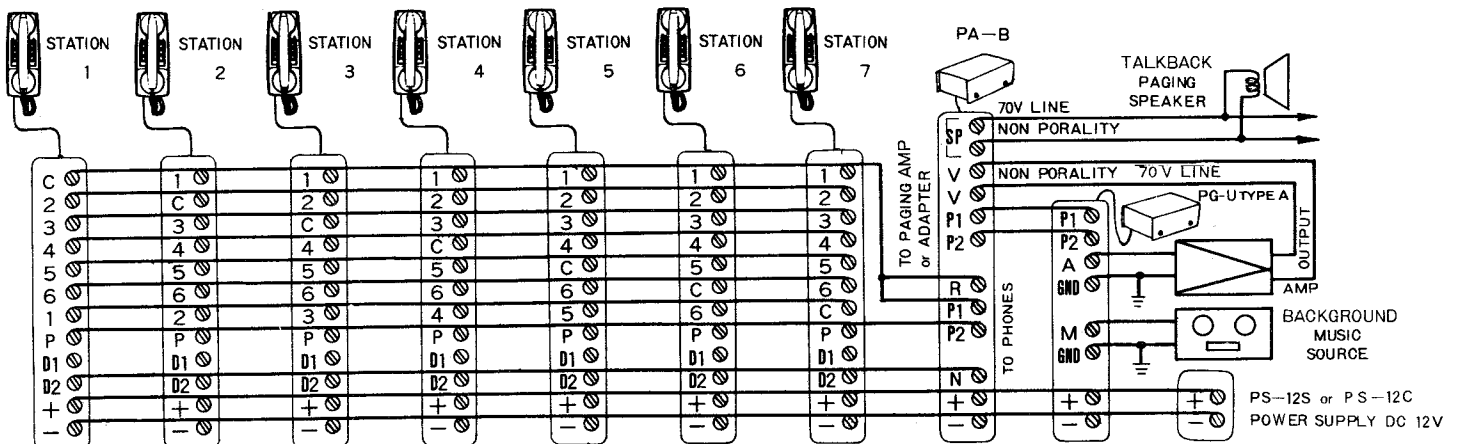

## MASTER/SUB SYSTEM

Any combination of TA-F series phones can be intermixed to develop a master-sub system to meet your requirements. The example below shows 6 TA-1F stations connected to 1 TA-6F.

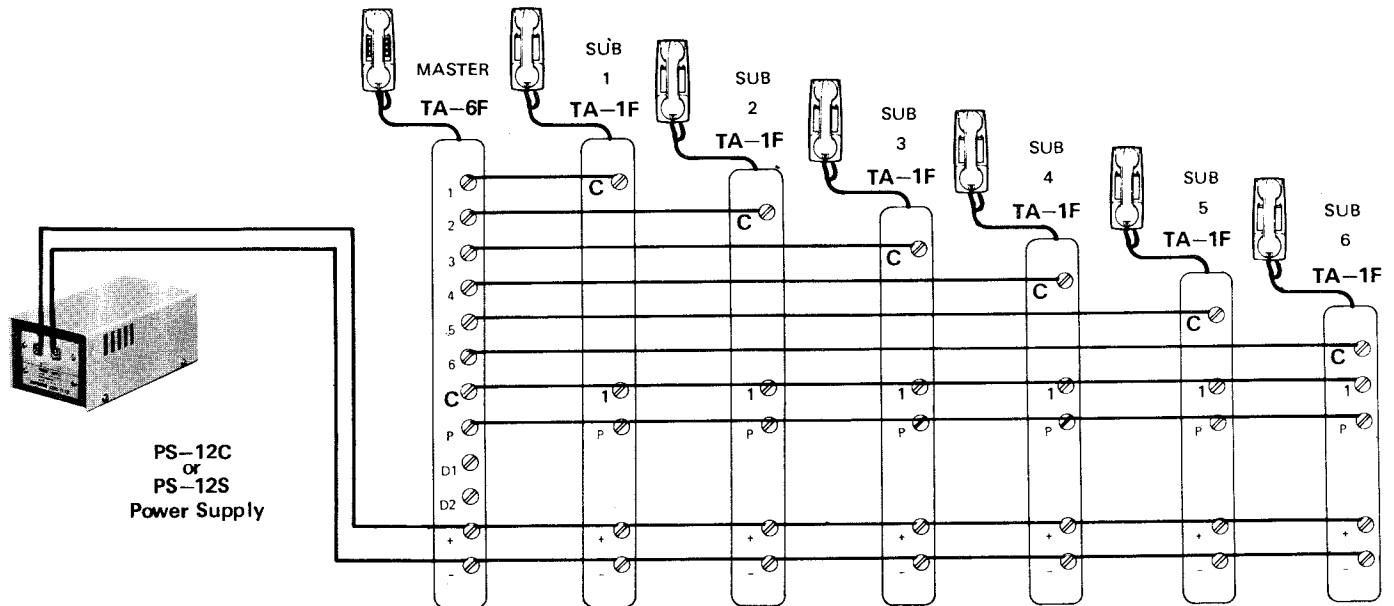

All stations have paging ability. Refer to paging diagram for proper connection to paging system.

## FIELD INSTALLATION OF NOISE CANCELLING HANDSET MODEL NCH-1

For extremely noisy areas, Aiphone has developed a special handset which allows excellent communication from a phone in a noisy area to other phones in the communication system. Designed to work with Aiphone Model TA-F, this handset contains an amplifier for communication and noise cancelling mouthpiece.

### TO INSTALL

- (a) Remove two screws on bottom of phone as shown, using a Phillips screw driver. (fig. 1)
- (b) Carefully lift the plastic case from the base.
- (c) Lift hook anchoring coil cord to metal base. (fig. 2)
- (d) Carefully remove red, white and black wires from printed circuit board using soldering iron.  
Remove old handset, and retain for spare parts.
- (e) Attach red, white and black wires from noise cancelling handset coil cord with soldering iron as shown.  
Be sure your wires are in the correct order. (fig. 3)
- (f) Bend hook back, (Note (c)), replace plastic case (Note (b)), and screws (Note (a)).

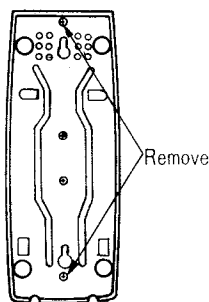

(fig. 1)

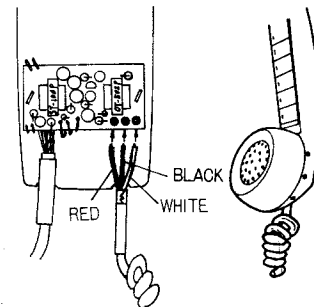
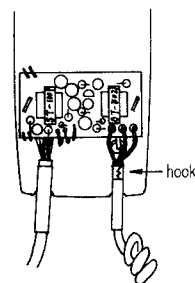

## INSTALLING EXTERNAL SIGNALING DEVICE RELAY

Example shows station 4 with relay RY-AC which switches an external light, bell, horn or buzzer (external signal devices not provided by Aiphone).

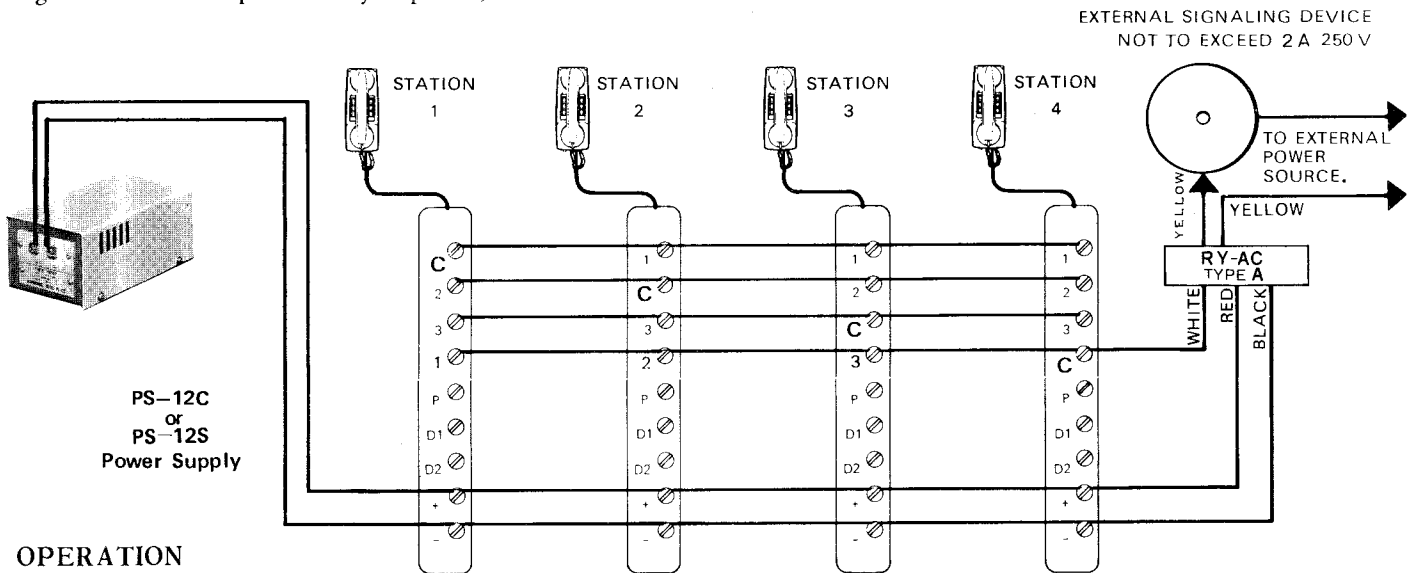

### OPERATION

**\* Calling:**

Pick up the handset and momentarily depress the selector button of desired station.

**\* Receiving:**

An incoming call is announced by an electronic tone. Pick up the handset and begin speaking.

### PAGING OPERATION

\* Pick up the handset and make announcement by pushing and holding the paging button. Background music will automatically cut out during paging operation.

### CLEANING YOUR INTERCOM STATIONS

\* Your Aiphone intercom stations may be cleaned with a soft cloth dampened with household cleanser, such as Mr. Clean or Fantastik.

\*\*\*

We at AIPHONE are proud of our products. Our designers and engineers strive to bring you the finest in communication equipment. Each item has been carefully tested and inspected before leaving our factory. Properly installed and used, your Aiphone intercom system should give years of trouble-free service.

We are pleased to offer the following warranty:

#### WARRANTY

Aiphone warrants its products to be free from defects of material and workmanship under normal use and service for a period of one year after delivery to the ultimate user and will repair free of charge or replace at no charge, should it become defective upon which examination shall disclose to be defective and under warranty. Aiphone reserves unto itself the sole right to make the final decision whether there is a defect in materials and/or workmanship; and whether or not the product is within the warranty.

This warranty shall not apply to any Aiphone product which has been subject to misuse, neglect, accident, or to use in violation of instructions furnished, nor extended to units which have been repaired or altered outside of the factory.

This warranty does not cover batteries or damage caused by batteries used in connection with the product.

This warranty covers bench repairs only, and any repairs must be made at the shop or place designated in writing by Aiphone. Aiphone will not be responsible for any costs incurred involving on site service calls.